

Expedient Homemade Firearms

The 9mm Machine Pistol



A Home Gunsmith Publication

Expedient Homemade Firearms:

The 9mm Machine Pistol

By P.A. Luty (D.F.C)

Copyright C.2004 by P. A. Luty.

A Home Gunsmith Publication

All rights reserved. Anyone attempting to reproduce any part of this publication in any form without the express written permission of the author will be tried, sentenced and shot, (and not necessarily in that order)

**Direct all enquiries/orders to:
www.thehomegunsmith.com**

Neither the author nor publisher assumes any responsibility for the use or misuse of the information contained in this book.

Introduction

Readers of '*Expedient Homemade Firearms*' Volume I and II may find the following 9mm Machine Pistol design of interest.

The firearm is constructed using similar materials and techniques as those illustrated in my previous books. The following construction drawings will be familiar to readers already conversant with my previous designs. The pistol uses the same design magazine shown in Volume I, though I have included the magazine base plate spring design, shown in Volume II, as a design improvement.

I have designed the bolt to be a simple unit easily machined using a lathe, rather than assembling the bolt from the selection of hardware products shown in Volume I and II.

In short, I have designed the machine pistol with the slightly more advanced home-gunsmith in mind and to enable relatively simple home workshop construction.

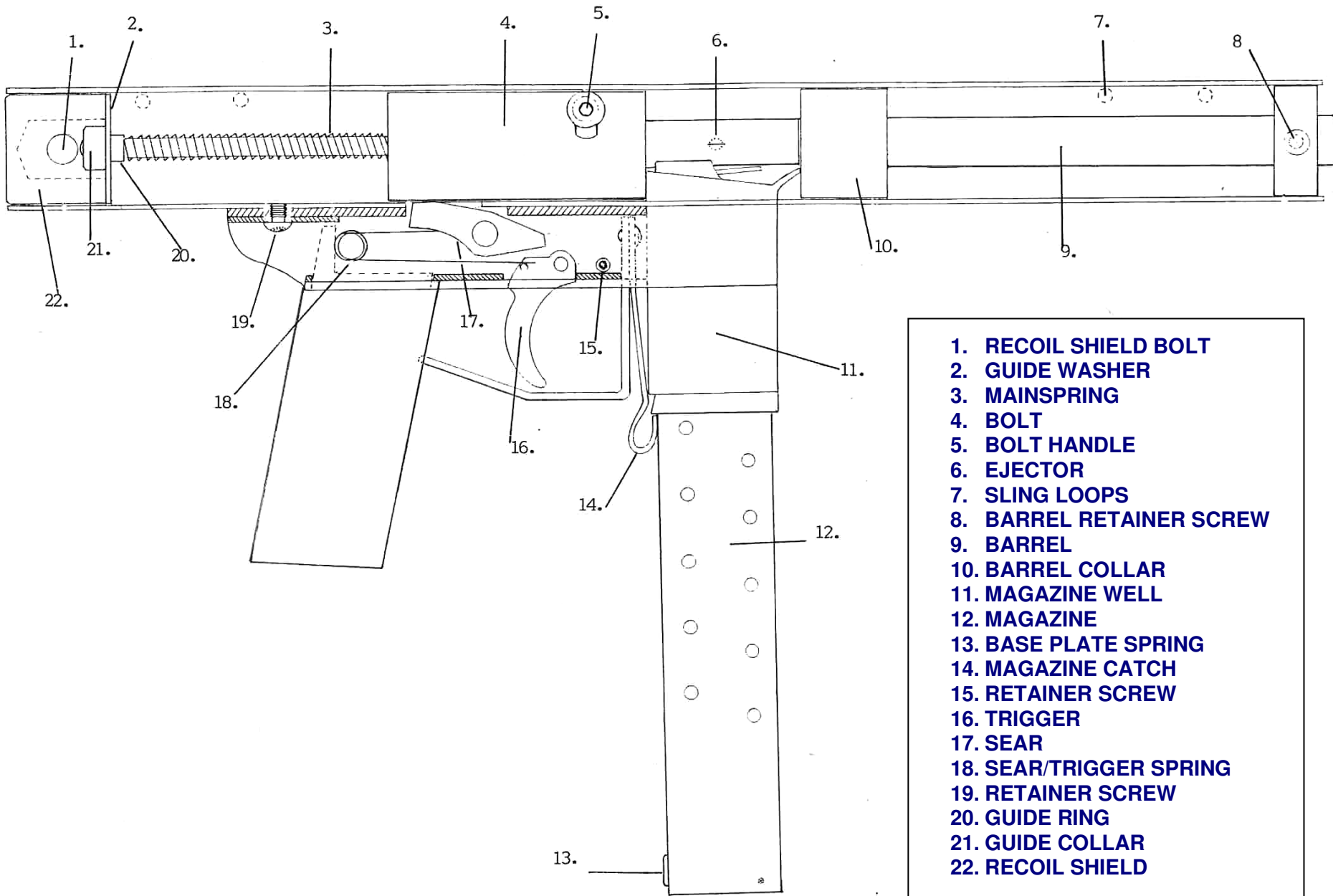

- 1. RECOIL SHIELD BOLT
- 2. GUIDE WASHER
- 3. MAINSPRING
- 4. BOLT
- 5. BOLT HANDLE
- 6. EJECTOR
- 7. SLING LOOPS
- 8. BARREL RETAINER SCREW
- 9. BARREL
- 10. BARREL COLLAR
- 11. MAGAZINE WELL
- 12. MAGAZINE
- 13. BASE PLATE SPRING
- 14. MAGAZINE CATCH
- 15. RETAINER SCREW
- 16. TRIGGER
- 17. SEAR
- 18. SEAR/TRIGGER SPRING
- 19. RETAINER SCREW
- 20. GUIDE RING
- 21. GUIDE COLLAR
- 22. RECOIL SHIELD

MATERIALS REQUIRED

TUBING

Upper Receiver	40 x 40 x 2.5mm
Lower Receiver	25.40 x 25.40 x 2.5mm
Magazine Well	40 x 20 x 2mm
Magazine	34.93 x 15.88mm
Trigger Group Receiver	20 x 20 x 2mm
Barrel	15.00 x 3.00mm

SPRING STEEL

Magazine Catch	7/16" x 18 Gauge Spring Steel
Mainspring	20 Gauge Spring Wire

FLAT BAR

Trigger Guard	5/8 x 1/8" Flat Bar
---------------	---------------------

TOOL STEEL

Sear	3/8" Plate
Trigger	1/4" Plate

ROUND BAR

Bolt	35mm Dia'
------	-----------

Note: Measurements are supplied in either Metric or Imperial sizes in accordance with the measurements materials are usually encountered.

TEMPLATES

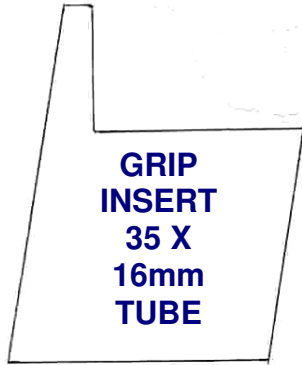

**GRIP
INSERT
35 X
16mm
TUBE**



**MAGAZINE
WELL
40 x 20mm
TUBE**

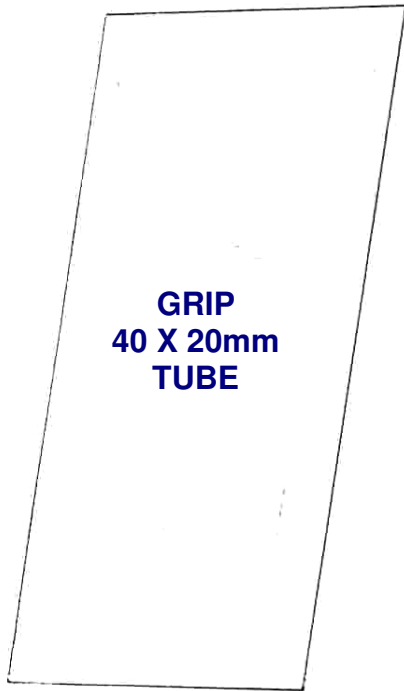

**GRIP
40 X 20mm
TUBE**



**MAGAZINE
CATCH
7/16" x 20g
SPRING STEEL**

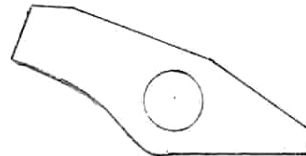

**SEAR
3/8"
TOOL STEEL**



**TRIGGER
1/4" PLATE**

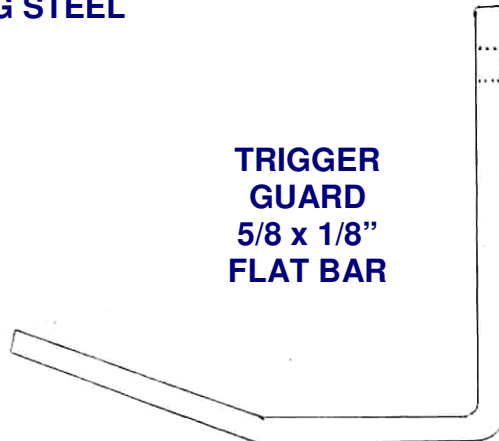

**TRIGGER
GUARD
5/8 x 1/8"
FLAT BAR**

TEMPLATES

LOWER RECEIVER

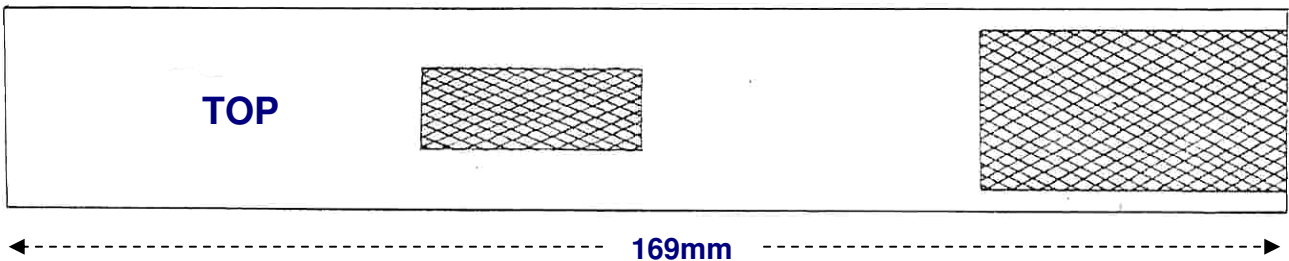

CUT OUT AND REMOVE SHADED AREAS.



HOLE POSITIONS.

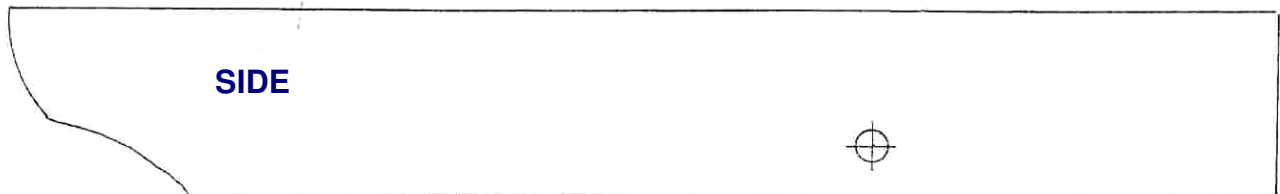

The overall length of the template is 169mm.

If the template is not 169mm in length when printed, it can be enlarged as necessary using a photocopier, until the above measurement is achieved.

TEMPLATES

TRIGGER GROUP RECEIVER

(Hole diameters not to scale)

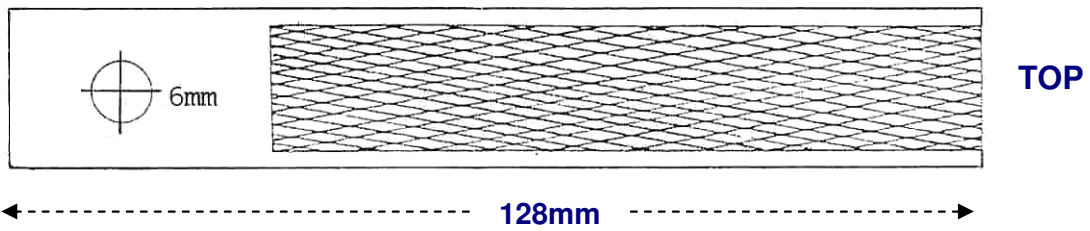

CUT OUT AND REMOVE SHADED AREAS.

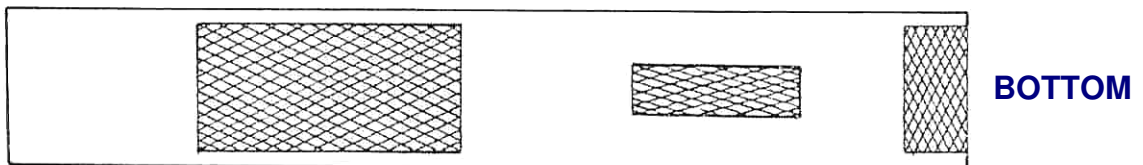
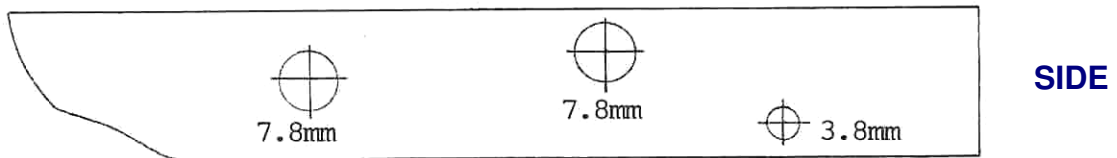

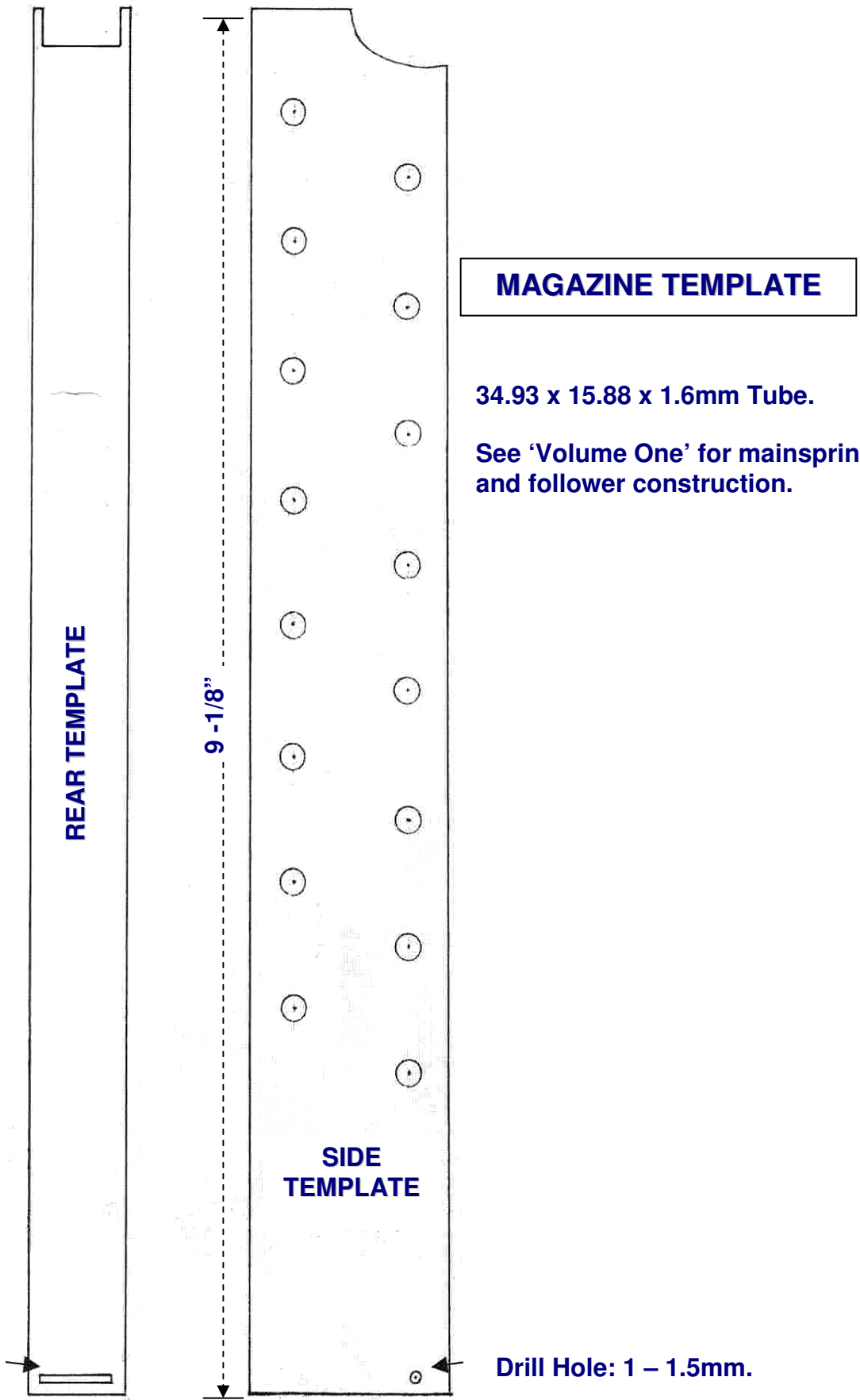

REAR TEMPLATE

9 - 1/8"

MAGAZINE TEMPLATE

34.93 x 15.88 x 1.6mm Tube.

See 'Volume One' for mainspring and follower construction.

SIDE TEMPLATE

Cut Slot 1 - 1.5mm deep to accept base plate spring retainer.

Drill Hole: 1 - 1.5mm.

Upper Receiver Recess Positions.
16 1/4" length of 40 x 40 x 2.5mm tubing
 (All measurements in millimeters)

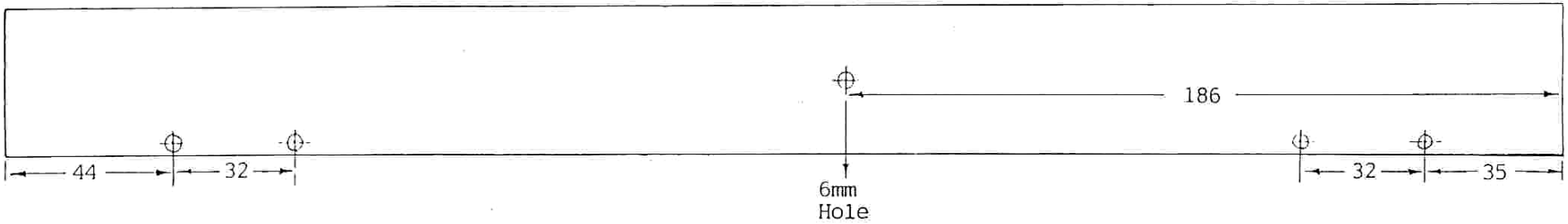
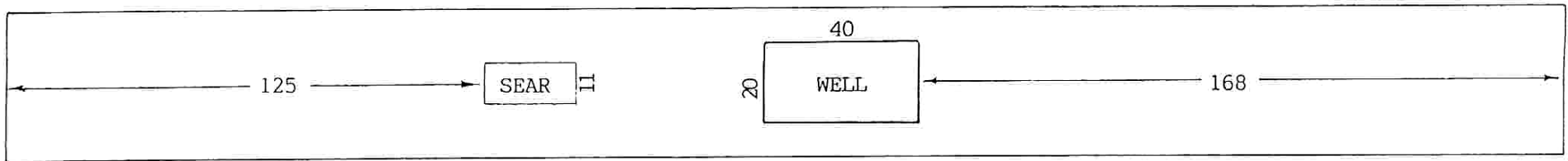
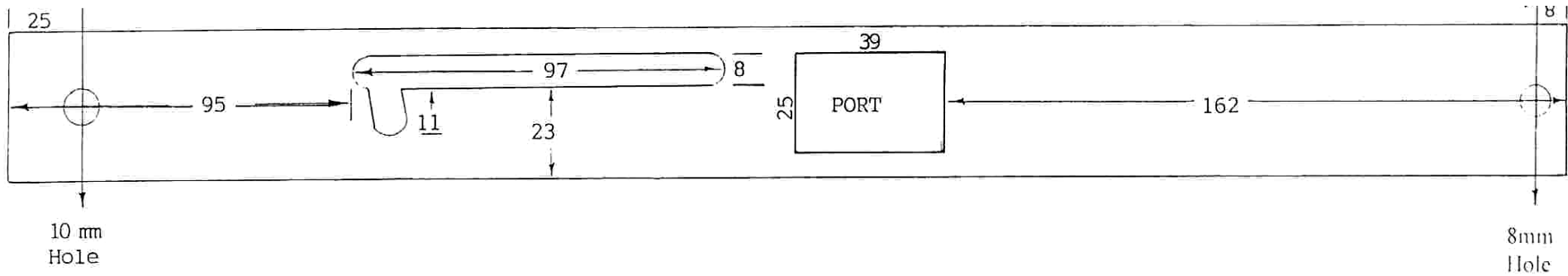

- 10 -

LOWER RECEIVER **CONSTRUCTION.**

The two templates are glued to a length of 1" x 1" x 12g tubing, as illustrated below.

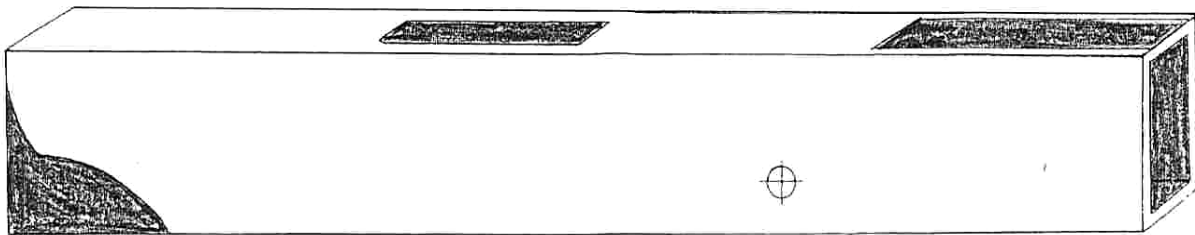

After cutting out, the receiver should look like the illustrated below.

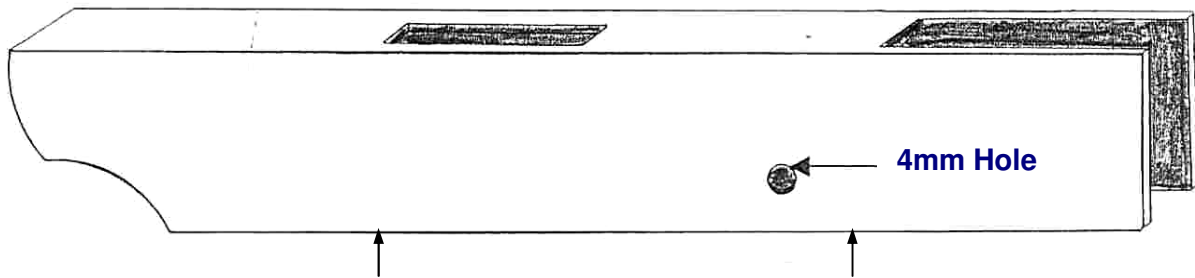

Completely cut out and remove bottom sidewall of receiver.

ASSEMBLING THE UPPER AND LOWER RECEIVERS

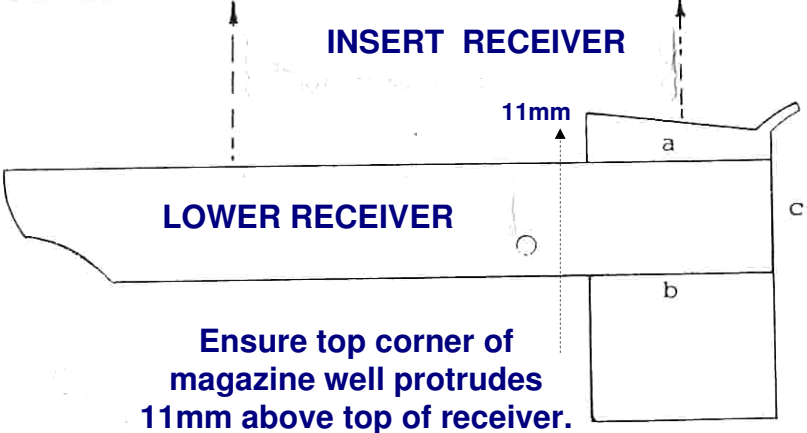
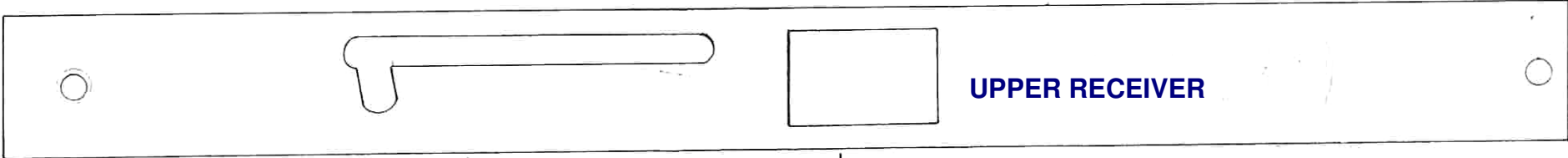

Ensure top corner of magazine well protrudes 11mm above top of receiver.

The magazine well is held in place by silver soldering at points 'a' and 'b' or welding at points 'c' and 'b'.

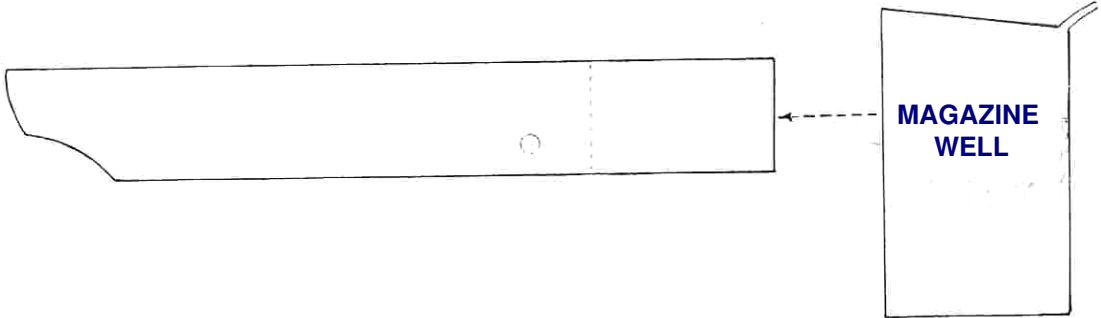

THE UPPER AND LOWER RECEIVER ASSEMBLY

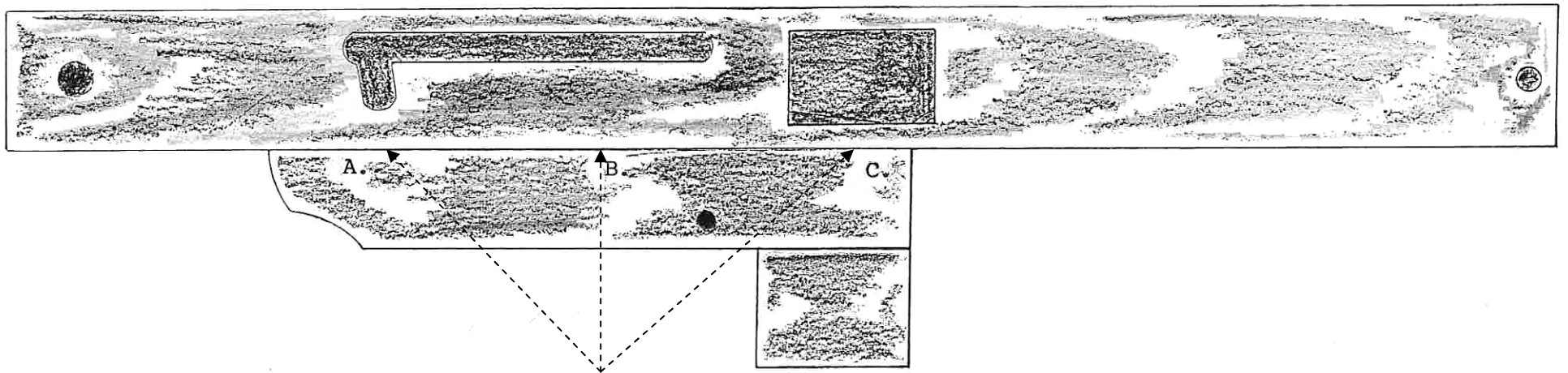

The two receivers are welded together at points 'a' 'b' and 'c'.

TRIGGER GROUP RECEIVER **CONSTRUCTION.**

The two templates are glued to a length of 20 x 20 x 2mm tube.

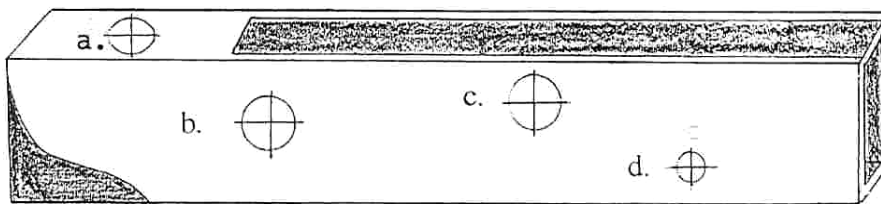

Hole diameters: a) 6mm, b) 7.8mm, c) 7.8mm, d) 3.8mm.
(Hole diameters not to scale)

After cutting out, the receiver should look like the one illustrated below.

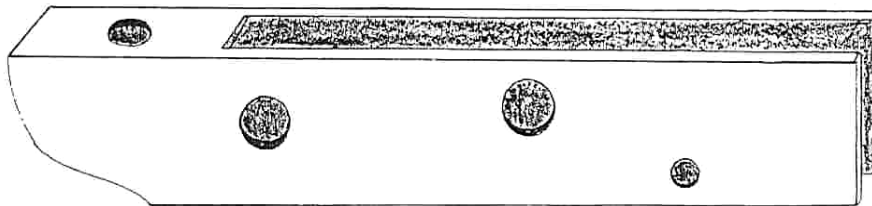

TRIGGER MECHANISM

The trigger mechanism consists of the sear, sear spring, trigger and magazine catch. The trigger group receiver is now ready to be fitted with all the above parts. See 'Templates'.

Sear

The sear is cut and shaped from a section of 3/8" (9.5mm) steel plate (tool steel/gauge plate, etc*) The sear pivot pin hole is drilled to a diameter of 8mm and accepts an 8mm diameter dowel pin, (Figure 4, Page 32) or similar hardened steel pin.

Trigger

The trigger is shaped from a 1/4" (6.35mm) thick section of tool steel/gauge plate, etc. The trigger pivot pin hole is drilled to a diameter of 4mm to accept a 4mm diameter dowel pin, or similar (Figure 10). The second trigger hole is drilled to a diameter of 2mm and accepts a pin of 2mm diameter (Figure 11). A spring pin may be used for this purpose. The trigger should then be polished to a smooth finish.

Magazine catch

The magazine catch (Figure 7) is formed to the correct shape by bending a length of 7/16" spring steel strip material to the shape of the magazine catch template. The catch should be made from 18 or 20 gauge spring steel using the same simple methods described earlier in Expedient Homemade Firearms Volume II. The spring is bolted to the front section of the trigger guard (Figure 6). The hole in the front of the guard may be tapped to accept a 4mm diameter socket screw, or the catch can be secured with a simple nut and bolt arrangement.

Sear and Trigger Spring

The sear and trigger spring is formed by bending a length of 20 gauge spring wire around an 8mm diameter mandrel (steel rod). The shape and design of the spring will be self explanatory from the drawing (Figure 1). When the trigger, sear, and sear spring are fitted, it should be noted that the dowel pins must not protrude beyond the outer surface of the receiver wall.

The parts must be fitted in the correct order, i.e., the trigger first, followed by the spring and sear. Finally, ensure all parts are moving freely and make any necessary adjustments.

Note*. 'Gauge Plate' is readily available from any good model engineering store and from some tool shops and ironmongers, etc. Each length of plate is sold with its own hardening and tempering instructions and the hardening process can be easily carried out with an ordinary propane gas torch. Although not an 'ideal' steel for the purpose, its ready availability makes it an obvious choice for trigger and sear construction in the improvised firearm.

Note: The sear and trigger could be made quiet easily from a piece of mild steel, and case hardened using 'Kasenit' case hardening powder as a cheaper alternative to tool steel.

TRIGGER GROUP COMPONENTS

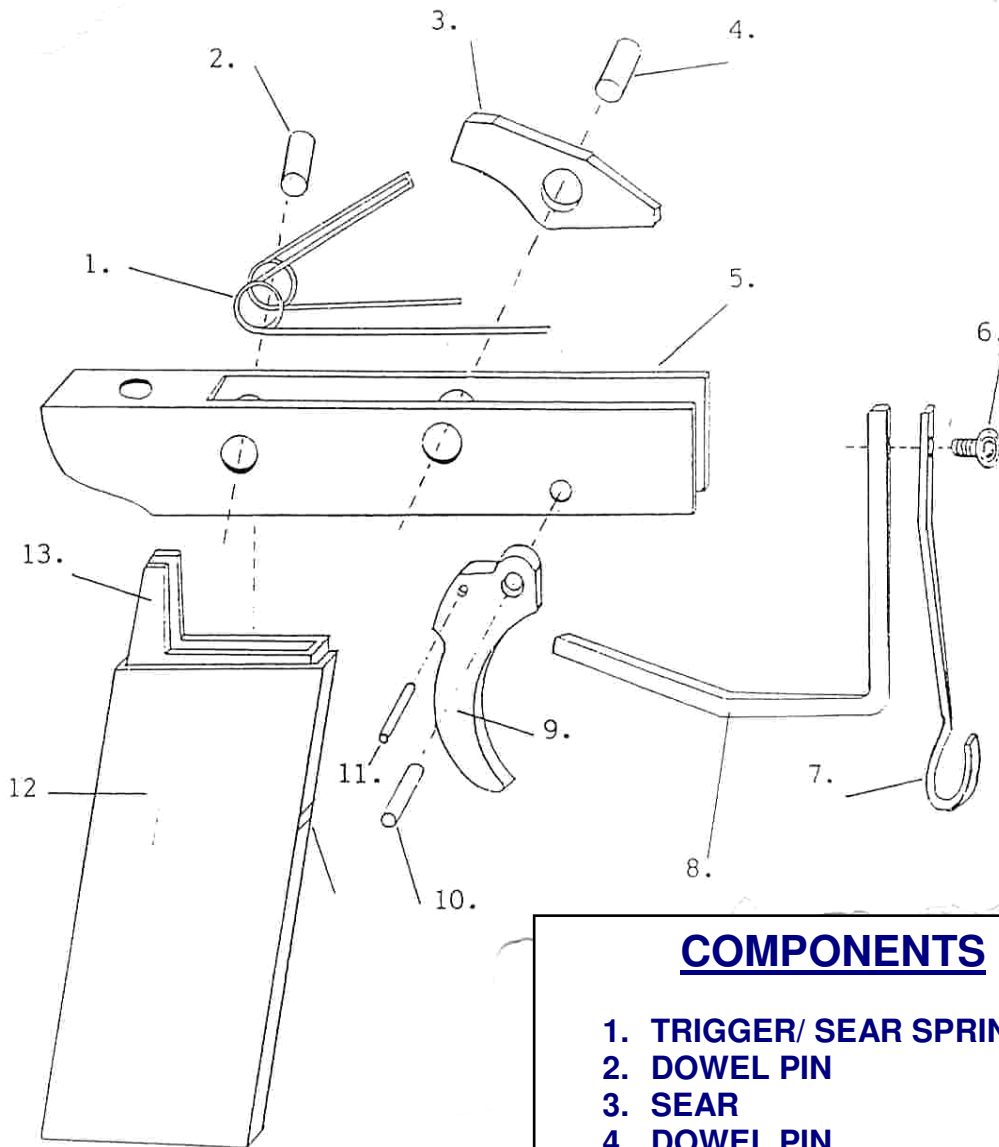

COMPONENTS

1. TRIGGER/ SEAR SPRING
2. DOWEL PIN
3. SEAR
4. DOWEL PIN
5. RECEIVER
6. MAGAZINE CATCH SCREW
7. MAGAZINE CATCH
8. TRIGGER GUARD
9. TRIGGER
10. DOWEL PIN
11. DOWEL PIN
12. GRIP
13. GRIP INSERT

ASSEMBLING THE RECEIVER

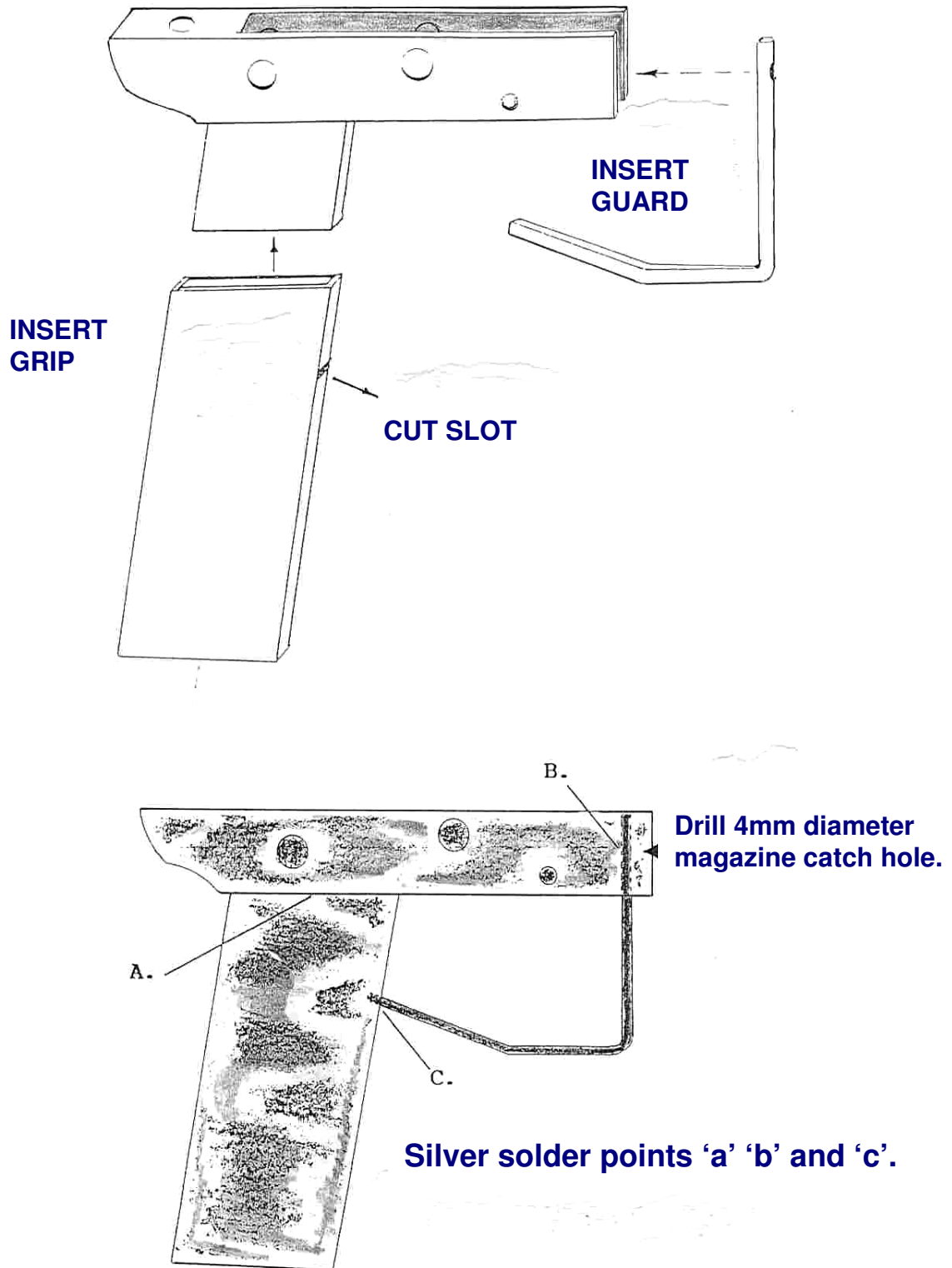

TRIGGER GROUP **AND GRIP ASSEMBLY**

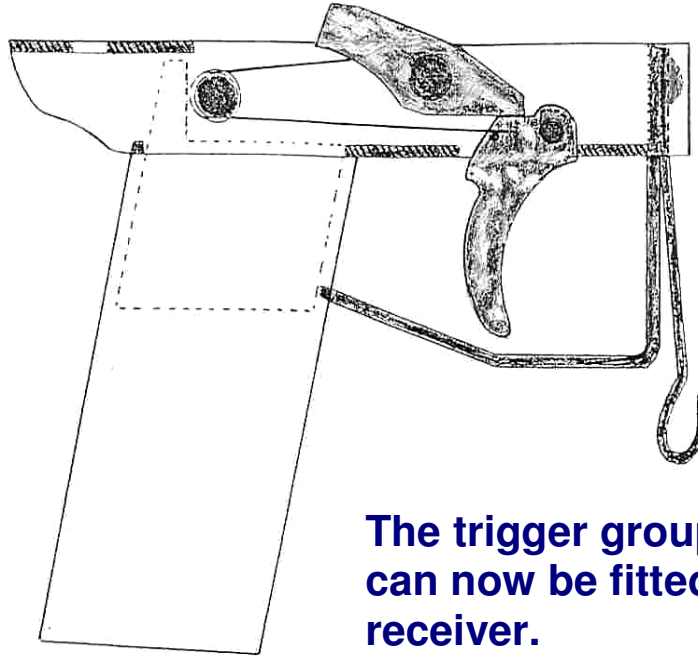

**The trigger group assembly
can now be fitted to the lower
receiver.**

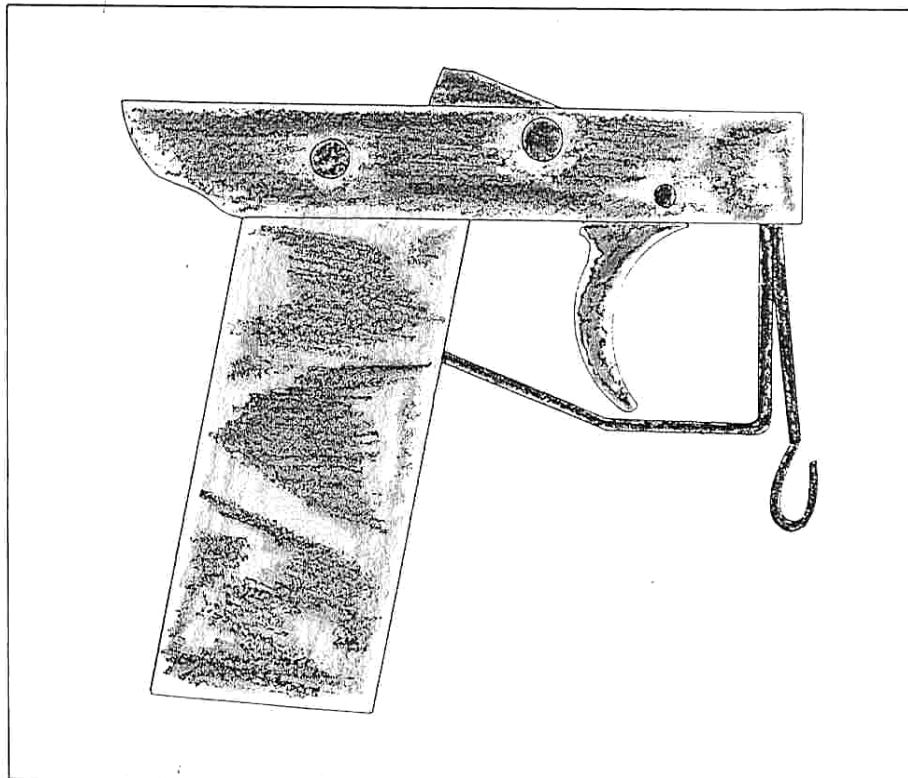

FITTING THE TRIGGER GROUP RECEIVER

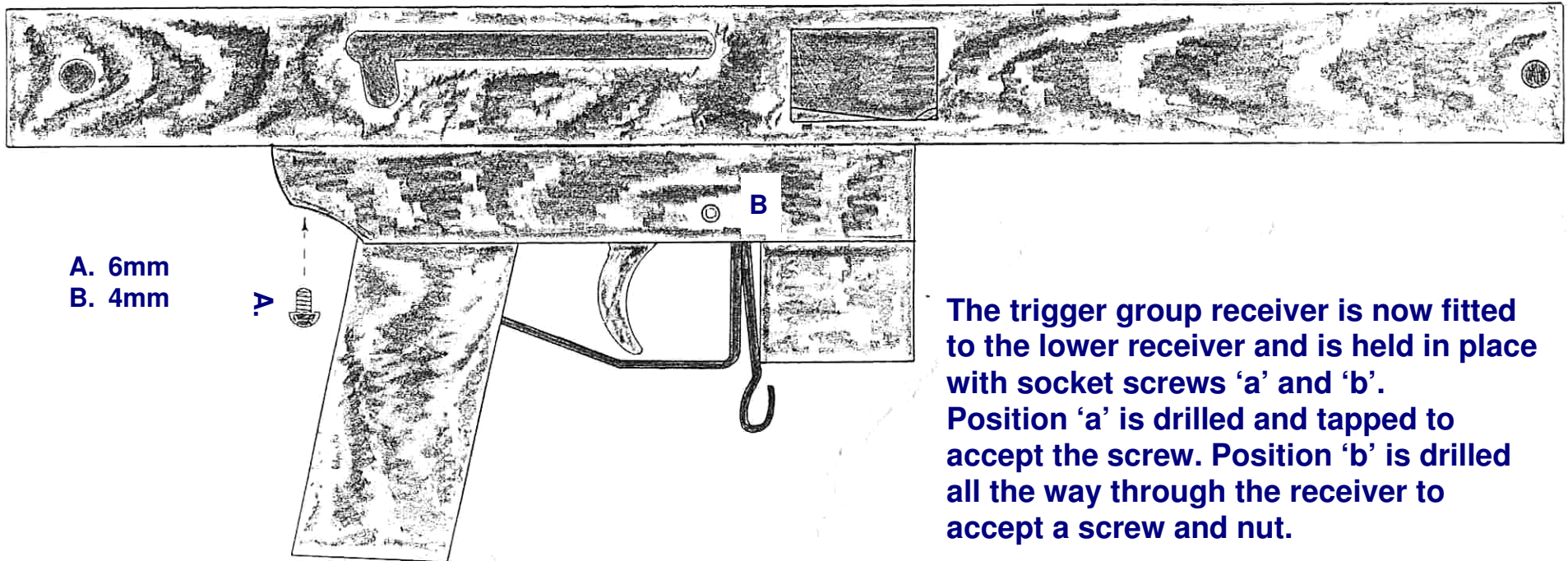

The trigger group receiver is now fitted to the lower receiver and is held in place with socket screws 'a' and 'b'. Position 'a' is drilled and tapped to accept the screw. Position 'b' is drilled all the way through the receiver to accept a screw and nut.

The magazine is now constructed and fitted.

MAGAZINE CONSTRUCTION

(The magazine is made from a length of 34.93 x 15.88mm 16g tubing, using the same techniques shown in 'Expedient Homemade Firearms', Volume One)

FORM BLOCK

The form block is made from a length of 1" x ½" flat steel bar.

MAGAZINE LIPS

The magazine lips should be set 9mm apart.

MAGAZINE SPRING

The magazine spring is coiled using 20 gauge spring wire.

MANDREL

The magazine spring mandrel is made from three 14" lengths of 8mm diameter steel rod, brazed/silver soldered together.

FOLLOWER

The follower is formed from a length of steel sheet, 2 ½" in length and ½" in width.

BASE PLATE SPRING

The base plate spring is formed from 20 gauge spring wire.

BARREL CONSTRUCTION

(All measurements in millimeters)

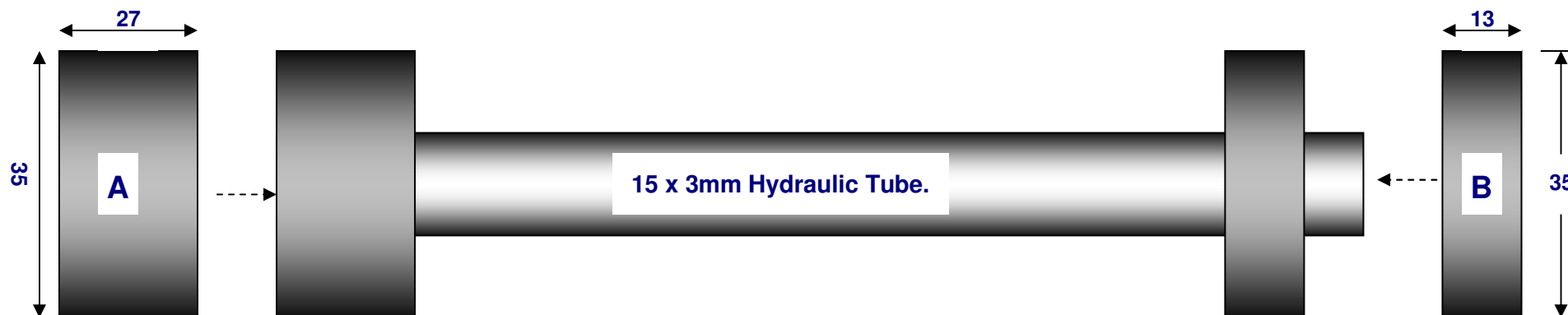

The barrel overall length is 6 1/2".
The two collars are machined to the above dimensions and inserted onto the barrels breech and muzzle.
Collar 'A' is retained with bearing adhesive.
Collar 'B' is silver soldered in place.

RECOIL SHIELD DIMENSIONS.

(Measurements in millimeters)

The recoil shield is machined to the following dimensions.

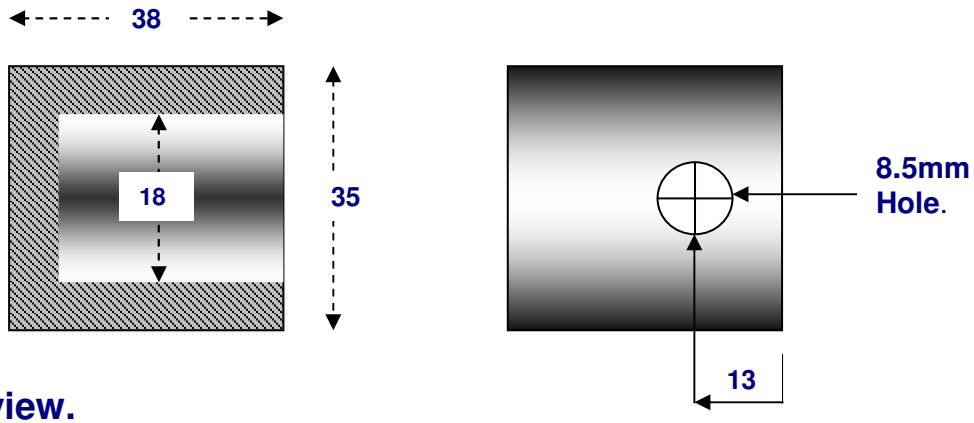

Cut away view.

GUIDE ROD

The measurement between washer and tip of guide rod should be 88mm.

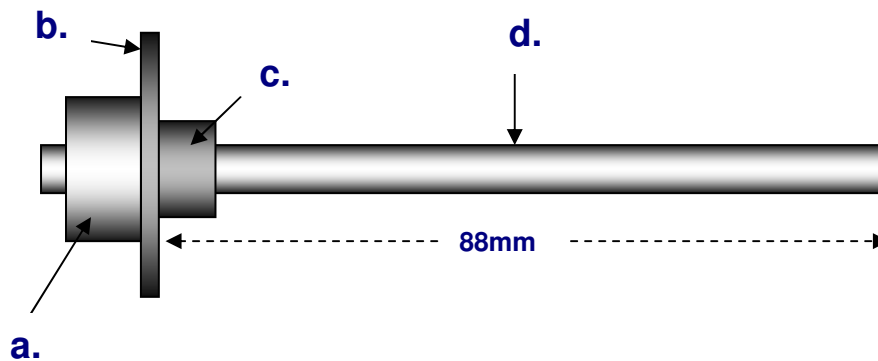

A: 6mm Shaft Lock Collar.

B: Washer.

C: Steel Ring (Tube section-8mmOD max) Solder in place.

D: 6mm (or 1/4") Rod.

CUT AWAY VIEW OF RECOIL SHIELD AND GUIDE ASSEMBLY

Cut away view.

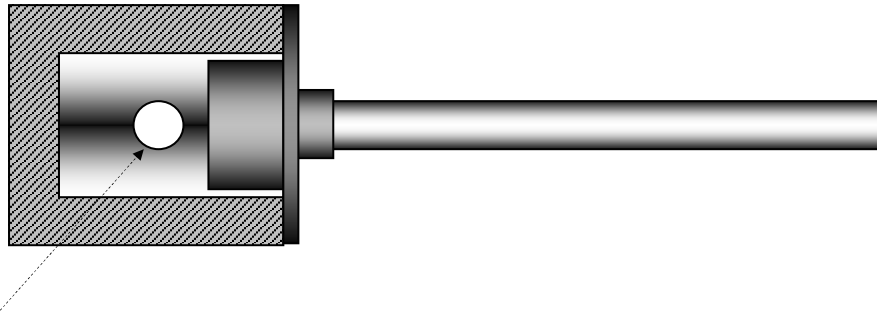

Recoil Shield Bolt Hole.

The recoil shield bolt hole should be tapped to accept two 10mm diameter high tensile socket screws. The two socket screws retain the recoil shield within the upper receiver.

MAINSRING

The mainspring is coiled around a 5.5mm (7/32") mandrel to a length of 14" using 20 gauge spring wire. Following 'compression shrinkage', trim the spring to a length of 10". See *'Expedient Homemade Firearms'* Volume One, for full spring coiling techniques.

BOLT CONSTRUCTION

As illustrated in ‘Expedient Homemade Firearms’ Volume Two, the bolt for the 9mm machine pistol must be machined from a suitable steel.

Machining the bolt is a relatively simple turning procedure. Start with a section of round bar, 35mm in diameter and machine the bolt to the following dimensions.

Bolt outside diameter (A1) is 35mm and the bolts overall length (OAL) is 127mm. Machine the front section (A2) to an OAL of 48mm and a diameter of 14mm (A3).

Mainspring/guide recess (B1). Using a 5.5mm drill bit, the recess B1 is machined to a depth of 93mm. Using a 9mm diameter drill bit the recess is re-bored to a depth of 74mm.

Cartridge recess: The cartridge recess (B2) is 10mm in diameter and 2.5mm in depth.

Ejector slot (C1) is cut to a depth of 3.5mm. The slot is 30mm in length and has a width of 3mm (C2). The slot may be cut by drilling a series of holes to remove most of the steel before trimming the slot to its correct dimensions.

Firing pin (D1) dowel pin/drill shank, etc, is 2mm in diameter and seated to a depth of 12mm. The pin must protrude from the face of the cartridge recess by 1.5mm (D2).

Bolt handle hole (E1) is machined 18mm from the front face of the bolt and is tapped to accept an 8mm diameter socket screw. The bolt handle hole is drilled to a depth of 10mm and must not cut through into the mainspring recess.

Note: The ejector slot is the final recess to cut. Before the slot can be made its correct position on the bolt radius must be marked. To do this simply insert the bolt into the receiver and screw in the bolt handle. Insert a pointed implement, nail/scribe etc, through the ejector hole and scribe the position of the slot onto the bolt by simply drawing the bolt back and forth. Cut the slot at this position to the dimensions given at C 1 and C 2.

BOLT DIMENSIONS

(All measurements in millimeters)

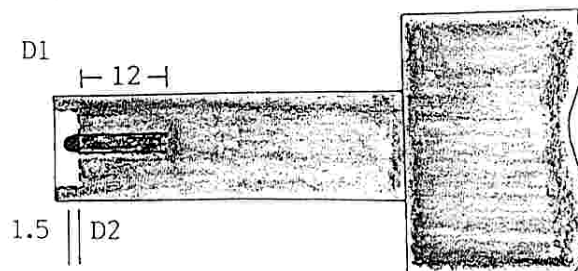
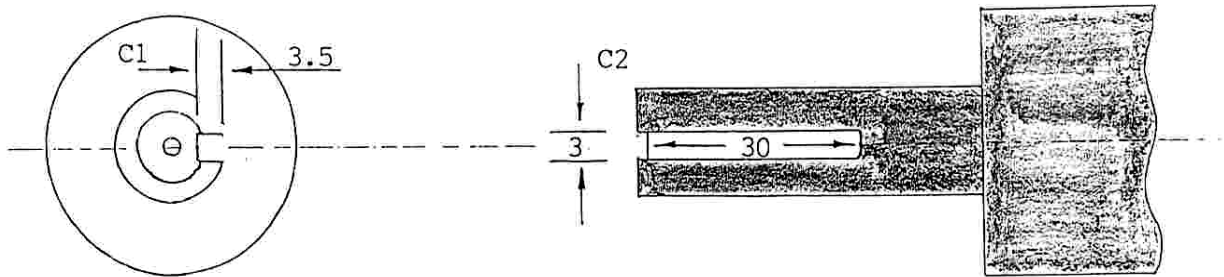
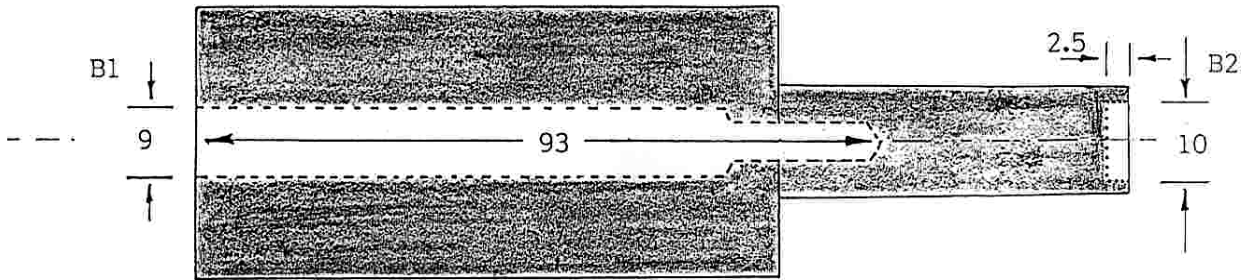
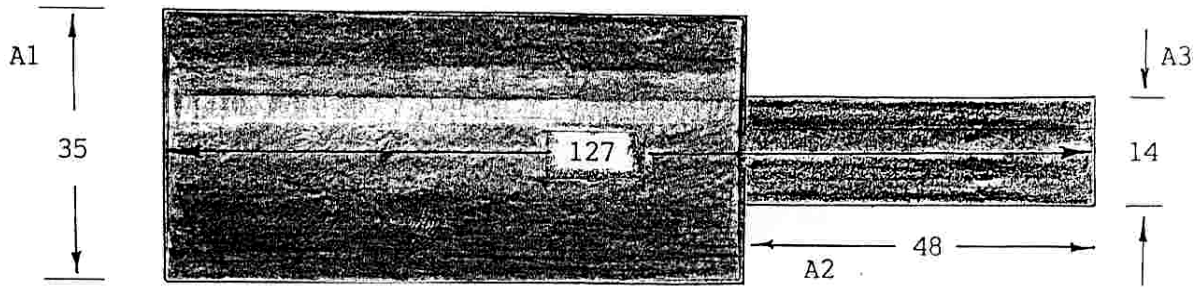

BOLT HANDLE POSITION.

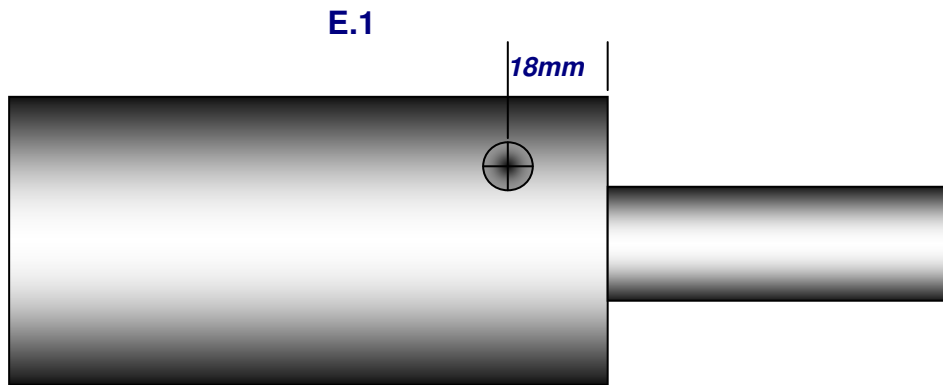

The bolt handle hole is drilled 18mm from the front face of the bolt.

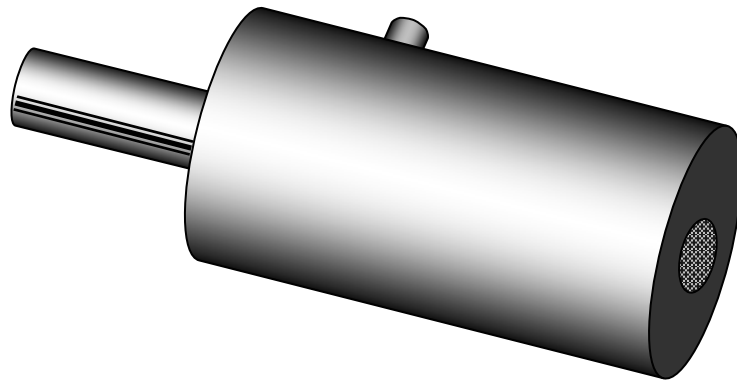

The Finished Bolt.

**THE RECOIL SHIELD, GUIDE ROD, BOLT AND BARREL
SHOWN IN THEIR RESPECTIVE POSITIONS.**

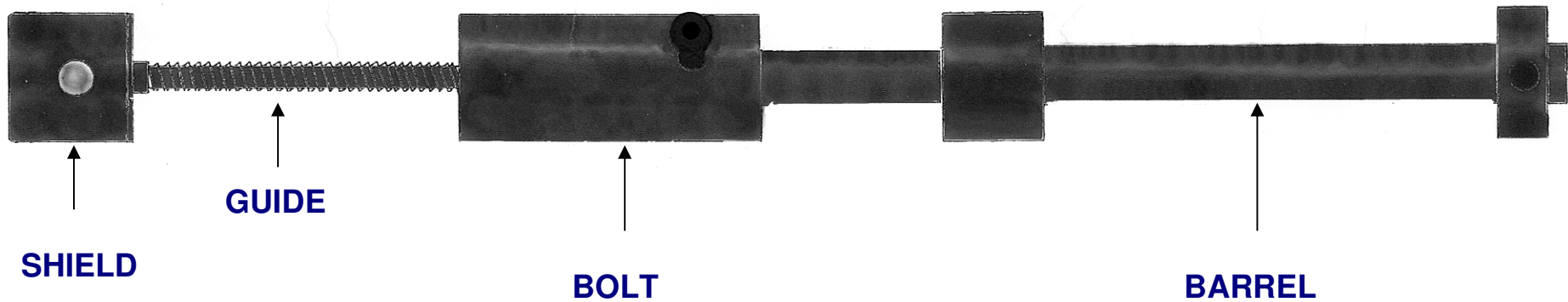



THE MACHINE PISTOL'S MAJOR COMPONENT PARTS.